



Flowmeter Product Directory

MODEL : AMO-1



FEATURES

- 본제품은 전체가 금속제로서 높은 압력과 온도에 견딜 수 있는 견고한 유량계이며 AMC 모델과 달리 큰 유량을 측정할 수 있도록 설계 되어 있으며 산업분야에 광범위하게 사용된다.
- 현장지시(Local Indicator), 알람·경보(Alarm Contact) 시그널 출력형(4-20mA Output)으로 구분되는 통합형 유량계로서 주변기기와 조합되어 현장뿐 아니라 원격 제어가 가능한 것이 본 제품의 특징이다.

SPECIFICATION

CON'N	SIZE	MAT'L	PRESS.		TEMP.		ACCURACY	
							H ₂ O	GAS
FLANGE	15A-200A	STEEL	ST.	10kgf/cm ²	ST.	120℃	FS	FS
		SUS304 SUS316	SP.	20kgf/cm ²	SP.	200℃	±1.5%	±2.0%

MODEL CODE

AMO	-	<input type="checkbox"/>	-	<input type="checkbox"/>	-	<input type="checkbox"/>	-	<input type="checkbox"/>	DESCRIPTION	
FLOW DIRECTION		1							BOTTOM - TOP	
TYPE				1000					LOCAL INDICATOR	
				2000					INDICATOR WITH ALARM	
				3000					INDICATOR WITH ELECTRIC SIGNAL (4-20mA)	
				4000					INDICATOR WITH ELECTRIC SIGNAL AND INTEGRATOR WITH PULSE OUTPUT	
MATERIAL						1			STEEL	
						2				SUS304
						3				SUS316
						0				OTHER
CONNECTION								J	JIS 10K RF (FF)	
								A	ANSI 150# RF (FF)	
								D	DIN PN10/16	
								0	OTHER	



Flowmeter Product Directory

MODEL : AMO-1

FLOW RATE						
SIZE	DIVIDE	STANDARD	GENERAL		LOSS	LENGTH (mm)
		H ₂ O(m ³ /h)	LIQUID (m ³ /h)	AIR (Nm ³ /h)	mmH ₂ O	L
15A	1/2B	0.1 - 1.0	0.02 - 0.2 0.2 - 2	0.6 - 6 3 - 30	600	350
20A	3/4B	0.2 - 2.0	0.08 - 0.8 0.35 - 3.5	1.6 - 16 5 - 50	600	400
25A	1B	0.4 - 4.0	0.1 - 1 0.6 - 6	2 - 20 9 - 90	600	400
32A	1 1/4B	0.6 - 6.0	0.1 - 1 1 - 10	2 - 20 15 - 150	600	400
40A	1 1/2B	0.8 - 8.0	0.2 - 2 1.5 - 15	4 - 40 20 - 200	800	400
50A	2B	1.5 - 15	0.5 - 5 2.5 - 25	6 - 60 40 - 400	800	450
65A	2 1/2B	2.5 - 25	0.8 - 8 4 - 40	10 - 100 60 - 600	800	500
80A	3B	4 - 40	1.2 - 12 5 - 50	12 - 120 80 - 800	800	500
100A	4B	6 - 60	2.5 - 25 9 - 90	25 - 250 120 - 1200	1000	500
125A	5B	10 - 100	4 - 40 15 - 150	40 - 400 200 - 2000	1100	600
150A	6B	14 - 140	6 - 60 20 - 200	60 - 600 300 - 3000	1200	700
200A	8B	20 - 200	10 - 100 28 - 280	100 - 1000 400 - 4000	1500	800

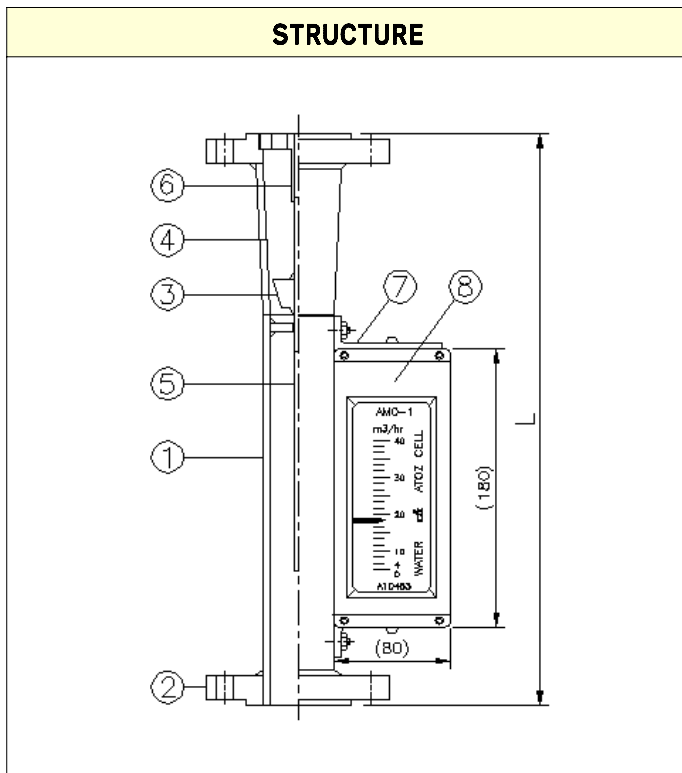

PART LIST

NO	NAME	MATERIAL		
		NO.1	NO.2	NO.3
1	Body	SUS304	SUS304	SUS316
2	Flange	SS400	SUS304	SUS316
3	Float	SUS304	SUS304	SUS316
4	Taper Tube	SS41	SUS304	SUS316
5	Magnet Rod	SUS304 ALNICO	SUS304 ALNICO	SUS316 ALNICO
6	Guid Stopper	SS41	SUS304	SUS316
7	Support	SS41	SUS304	SUS316
8	Housing	ADC12		