



# Flowmeter Product Directory

MODEL : ATH-2



## FEATURES

- 오수, 폐수 및 불투명 유체 측정에 적합 하도록 설계 되어 있다.
- 투명한 지시부를 통해 직접적으로 유량 관찰 및 측정을 할 수 있다.
- 용도에 따라 Alarm Switch(On,Off)를 부가 할 수 있다.

## SPECIFICATION

CON`N	SIZE	MAT`L	PRESS.	TEMP.	ACCURACY
FLANGE	15A-200A	STEEL	MAX 10kgf/cm2	MAX 120℃	FS ±2.0%
		SUS304			
		SUS316			

MODEL CODE										
ATH	-	<input type="checkbox"/>	-	<input type="checkbox"/>	-	<input type="checkbox"/>			DESCRIPTION	
FLOW DIRECTION		2							BOTTOM - TOP SIDE	
MATERIAL				1					STEEL	
				2					SUS304	
				3					SUS316	
				4					PVC	
				0					OTHER	
CONNECTION						J			JIS 10K RF (FF)	
						A				ANSI 150# RF (FF)
						D				DIN PN10/16
						0				OTHER
CONTACT							W		WITHOUT	
							1			ONE POINT ALARM



# Flowmeter Product Directory

MODEL : ATH-2

FLOW RATE																
DIVIDE Float Size	STANDARD H <sub>2</sub> O (m <sup>3</sup> /h)	GENERAL			LOSS (mmH <sub>2</sub> O)		LIMIT (kgf/cm <sup>2</sup> )		WEIGHT (kg)		LENGTH (mm)					
		LIQUID (m <sup>3</sup> /h)		AIR (Nm <sup>3</sup> /h)	H <sub>2</sub> O	AIR	SUS	PVC	SUS	PVC	M	N	L			
		SUS304	SUS304	PVC										SUS304		
15A	0.1 - 1	0.02 - 0.2	0.05 - 0.5	0.6 - 6	250	150	10	3	6	2	400	80	670			
		0.2 - 2	0.15 - 1.5	3 - 30												
20A	0.2 - 2	0.08 - 0.8	0.1 - 1	1.6 - 16	300	200	10	3	7	2						
		0.35 - 3.5	0.25 - 2.5	5 - 50												
25A	0.4 - 4	0.1 - 1	0.1 - 1	2 - 20	300	200	10	3	10	2.5						
		0.6 - 6	0.4 - 4	9 - 90												
32A	0.6 - 6	0.1 - 1	0.1 - 1	2 - 20	300	200	9	3	12	3	420	100	710			
		1 - 10	0.8 - 8	15 - 150												
40A	0.8 - 8	0.2 - 2	0.2 - 2	4 - 40	300	200	9	3	13	3						
		1.5 - 15	1.2 - 12	20 - 200												
50A	1.5 - 15	0.5 - 5	0.5 - 5	6 - 60	300	300	9	3	16	5	480	120	790			
		2.5 - 25	1.5 - 15	40 - 400												
65A	2.5 - 25	0.8 - 8	1.2 - 12	10 - 100	400	300	8	3	23	6.5				500	150	810
		4 - 40	3 - 30	60 - 600												
80A	4 - 40	1.2 - 12	1.5 - 15	12 - 120	400	300	8	2	30	10	550	180	980			
		5 - 50	4 - 40	80 - 800												
100A	6 - 60	2.5 - 25	3 - 30	25 - 250	500	300	8	2	45	14				600	220	1030
		9 - 90	7 - 70	120 - 1200												
125A	10 - 100	4 - 40		40 - 400	500	300	7		60		650	250	1090			
		15 - 150		200 - 2000												
150A	14 - 140	6 - 60		60 - 600	500	300	7		80					700	280	1230
		20 - 200		300 - 3000												
200A	20 - 200	10 - 100		100 - 1000	500	300	7		130		800	280	1230			
		28 - 280		400 - 4000												

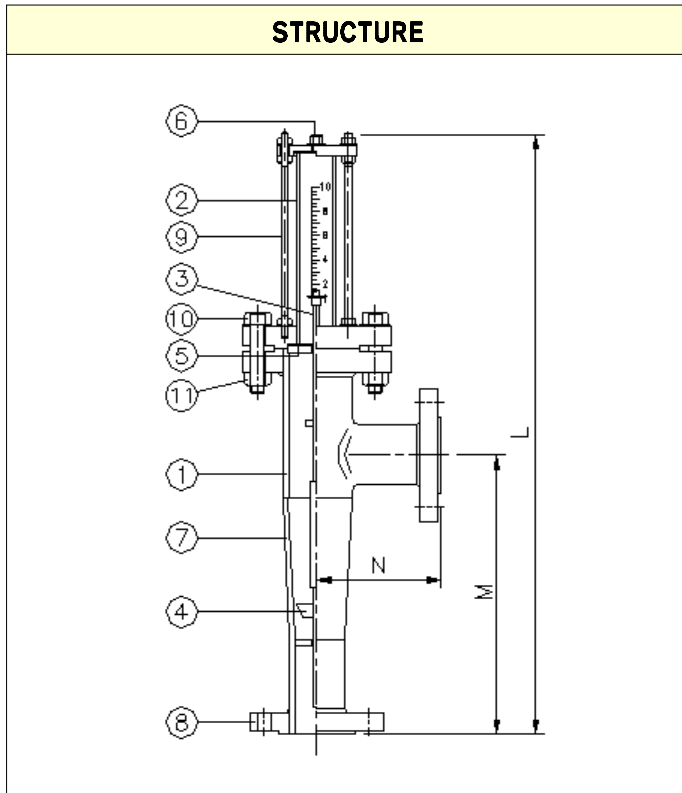

**PART LIST**

NO	NAME	MATERIAL			
		NO.1	NO.2	NO.3	NO.4
1	Body	SPP	SUS304	SUS316	PVC
2	Sight	ACRYL, PC, GLASS			
3	Index	SUS304	SUS316	PVC	
4	Float	SUS304	SUS316	PVC	
5	Packing	NBR, VITON, SILICON, TEFLON			
6	Vent Plug	SUS304	SUS316	SUS316	PVC
7	Tube	SUS304	SUS304	SUS316	PVC
8	Flange	SS400	SUS304	SUS316	PVC
9	Stay Bolt	STEEL	SUS304	SUS304	
10	Bolt	STEEL	SUS304	SUS304	
11	Nut	STEEL	SUS304	SUS304	